



Features

- Four Cores Intel® N97 Processor
- Industrial HMI Office Level EMC class B Certified
- Medical Grade UL/MDR Certification By Request
- Door Display with PoE for Customization
- Equipped with Power Button for User Friendly
- Fanless Type under 0~50°C Operation Temp.
- Compact Size Ideally for Limited Space Installation
- TPM 2.0 On Board

Specification

Product	WMP-109	
Main System	CPU	Intel® Alder Lake-N N97 Processor, 1.1GHz (up to 3.6G Hz), Max. TDP 6 W
	Graphic	Intel® Integrated UHD Graphics
	Memory	1 x DDR5 SO-DIMM sockets, Max. Capacity 16 GB Support Single Channel DDR5 4800 MHz memory modules
	TPM	TPM 2.0 On Board
	OS Support	Windows 10 IoT 2019 LTSC (64bit) / Windows 11 IoT LTSC
Display	Size	10.1"
	Resolution (pixel)	1280 x 800
	Number of Colors	16.7M Colors
	View Angle (H/V)	170(H) / 170(V)
	Brightness(cd/m ² , nit)	350 nits
	Contrast Ratio	800:1 (Typ)
Touch Panel	Type	Full Flat Projective Capacitive Touch Panel (Multi-touch)
	Light Transmission	90 ± 3%
	Hardness / Interface	7H pencil, pressure 750g/45° / Controller with USB interface, 5V
Storage & Expansion	Storage	1 X M.2 M-key 2280 SSD, Defaulted NVMe. 128G
	Expansion	1 x M.2 E-key 2230, 1 x Full Size Mini-PCIe w/SIM slot
I/O Ports	USB	2 x USB 3.2 Gen 2, 2 x USB 2.0
	COM	1 x RS232/422/485 (default is RS232, RS422 and RS485 are by manually change jumper setting on mother board)
	LAN	2 x RJ-45, Gigabit Ethernet
	Audio	Line Out, 1 x 3.5mm Phone Jack, 1 x 1.5W Speaker
	Video (output)	2 x HDMI
	Control Keys	Rear Bottom: Power on /off, ATX Switch
Power	Power Input	1 x 12~36 VDC-in
	Power Adapter	External, 63 Watts, Universal 100 ~240V AC in, 12V DC Out
	Power Consumption	TBD (12V)
Environmental	Temperature	Operating Temperature: 12V DC Input 0~50°C (IEC60068-2-78) Storage Temperature: -20~60°C
	Humidity	Operating & Storage: 10 ~ 90%, non-condensing
	Water/Dust resistance	Front IP65
Mechanical Characteristics	Housing	Silver Bezel / Black Cover
	Dimensions (Net: mm)	263.3 (H) x 171 (V) x 35.7 (T)
	Weights (Net: kg)	1.27 Kg (w.o. power adapter)
	Mounting	Chassis, VESA 75x75
Certification	FCC/ VCCI Class B (PSU with PSE), Canada ICES-003, CE-EMC IEC60601-1-2 (V4.1)	

WMP-109

Medical AIO Fanless Panel PC

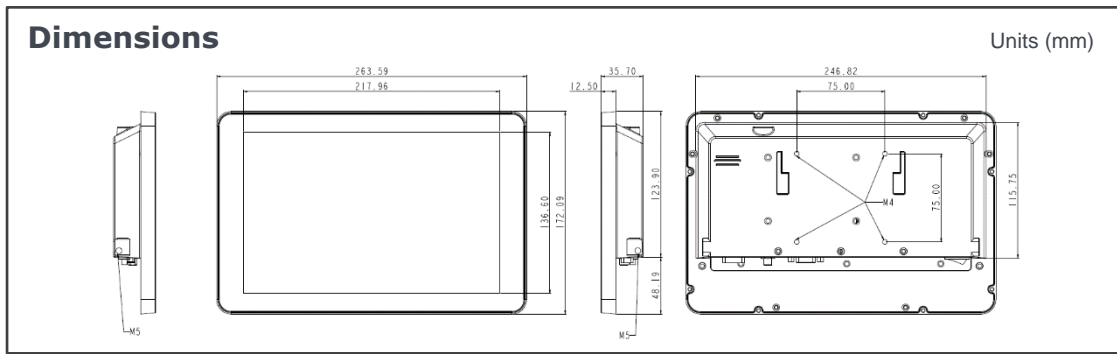

Major Options	
Options	<ol style="list-style-type: none"> 802.11 ac/a/b/g/n WLAN + Bluetooth 5.0 Module (802.11 ac/a/b/g/n WLAN antenna at top, bluetooth 5.0 antenna at I/O side) Ethernet RJ45 male to female right angle adapter x 2 Operation system: Windows 10 IoT 2019 LTSC (64bit) / Windows 11 IoT LTSC 128G M.2 NVMe SSD storage 8G RAM module
AP/API	<ol style="list-style-type: none"> Watch dog timer Hardware monitor Brightness control OSK (on screen keyboard)
Customization	<ol style="list-style-type: none"> Webcam (Can't co-exist with RFID) RFID (Can't co-exist with Webcam) COM x 2 (total) Panel mount kit White rear cover PoE function follows IEEE802.3at (30 Watt), supports wake on LAN function (not coexist with wireless, COM port, remove AC-DC power adapter and DC input connector) In wall mount bracket 3G/4G module Car ignition power control

Order Information

Item	Touch	Description
WMP-109	Chassis P-Cap.Touch	10.1" N97 3.6GHz, DDR5 8G RAM, 128G SSD, Full Flat P-Cap Touch

I/O ports



- 1 COM
- 2 DC-in
- 3 USB 2.0 x 2
- 4 USB 3.2 x 2
- 5 HDMI x 2
- 6 LAN x 2
- 7 WiFi Antenna (optional)
- 8 Power switch
- 9 Line out

