



Features

- Intel® Broadwell Core i7/i5 CPU
- 15" 1000nits Sunlight Readable LCD
- Wide Temp. -20~60°C Operation
- Full Flat Resistive Touch with Front IP66
- Front Panel Mount Housing
- Optional Mini-PCle WLAN with External Antenna
- CE, FCC, VCCI Class B Certified

Specification

Product		WLP-7D20-15H BKFT
Main System	CPU	Intel® 5th generation Core i7/i5/i3 processor
	Graphic	Intel® integrated HD Graphics by CPU
	Memory	Two 1600 MHz DDR3L SODIMM socket support dual Channel, non-ECC, up to 16GB
	OS Support	Win 7, Win 7pro, Win 8, Win 8 industrial, Win10
Display	Size	15" 4:3
	Resolution (pixel)	1024 x 768 (XGA)
	Number of Colors	16.7M colors
	View Angle (H/V)	160(H) / 160(V)
	Brightness(cd/m ² , nit)	1000 nits
	Contrast Ratio	700:1 (Typ)
Touch Panel	Type	Full flat resistive touch panel
	Light Transmission	80 ± 5%
	Hardness	4H
	Lifetime	35M times
Storage & Expansion	Storage	128GB 2.5" SATA SSD 3MG2-P x 1
	Expansion	Mini PCIe x 2
I/O Ports	USB	USB 3.0 x 2, USB 2.0 x 2
	COM	2 X RS-232, 1 X RS-232/422/485
	LAN	2 x RJ-45
	Audio/ Video	3.5mm phone jack connector x 2 (Line-out, Mic-in)/ DP x 2
	Control Keys	Rear bottom: Power on /off, reset
Power	Power input	DC-in x 1 , 7 ~ 32V
	Power adapter	External, 80 watts, universal 100 ~240V AC in, 12V DC out, 6.66 A
Environmental	Temperature	Operating Temperature: 12V DC Input -20~60°C (IEC 60068-2-56 air flow cooling) Storage Temperature: -20~60°C
	Humidity	Operating & Storage: 10 ~ 90%, non-condensing
	Water/Dust resistance	IP66 at front
Mechanical Characteristics	Housing	Front bezel is Aluminum, others are SECC with black coating
	Dimensions (Net: mm)	398 (H) x 330 (V) x 86 (T)
	Weights (Net: kg)	6 kg
	Mounting	Panel mount, VESA (75x75)
Certification	CE/ FCC/ VCCI Class B	

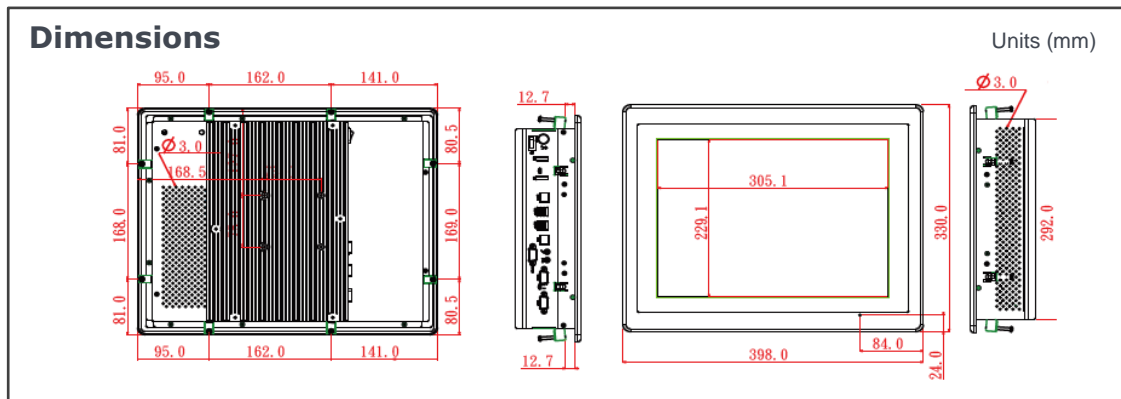

Major Options	
Add On Parts	1.Wireless or Wireless + BT kit , 2.Change to P-cap touch, 3. Stainless front bezel, 4. Silver front bezel, 5. 2.5" SSD, 6. mSATA module, 7. TPM
Add On Cable	1.DC input power plug (black, 1.22m length)
Customized	1.Open frame housing, 2.Sunlight readable optical bonding, 3.LCD auto dimming, 4.LCD super dimming (Low brightness), 5.Storage door Solution, 6.Chassis type housing

Order Information

Item	Touch	Description
WLP-7D20-15H (BKFT)	Full flat Resis.touch	15" Core i5 5200U/ Wide temp. 4G RAM/ 128G SSD

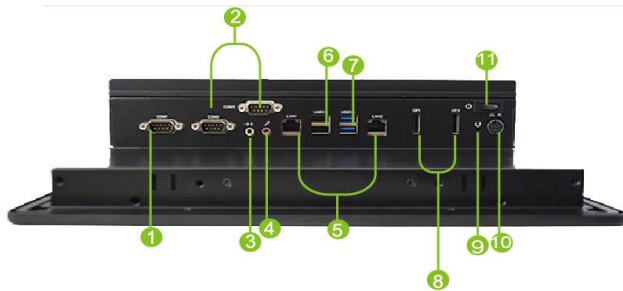

- ① RS232/422/485
- ② RS232 x 2
- ③ Line out
- ④ Microphone-in
- ⑤ LAN x 2
- ⑥ USB 2.0 x 2
- ⑦ USB 3.0 x 2
- ⑧ DP x 2
- ⑨ Reset
- ⑩ DC-in
- ⑪ Power on/off

