



Features

- Intel® Broadwell i7/i5 CPU
- 15" 1024 x 768 LCD Panel
- Chassis Type w/P-Cap Touch
- CE, FCC, VCCI Class B Certified
- Full Flat Design Easy Clean & IP66 Front
- Wide Range DC Input
- Optional WLAN with External Antenna

Specification

Product		WLP-7D20-15 CKPT
Main System	CPU	5th generation Intel® Core i7/i5/i3 processor
	Graphic	Intel® integrated HD Graphics 5500 by CPU
	Memory	Two 1600 MHz DDR3L SODIMM socket support dual Channel, non-ECC, up to 16GB
	OS Support	Win 7 pro, Win 8, Win 8 industrial
Display	Size	15" 4:3
	Resolution (pixel)	1024 x 768 (XGA)
	Number of Colors	16.7M colors
	View Angle (H/V)	160(H) / 160(V)
	Brightness(cd/m ² , nit)	450 nits
	Contrast Ratio	800:1 (Typ)
Touch Panel	Type	Chassis projective capacitive touch panel
	Light Transmission	90 ± 3%
	Hardness	7H
	Lifetime	100M times
Storage & Expansion	Storage	2.5" SATA HDD drive bay x 1 up to 500GB w/Anti-Vibration Kit
	Expansion	Mini PCIe x 2
I/O Ports	USB	USB 3.0 x 2, USB 2.0 x 2
	COM	2 X RS-232, 1 XRS-232/422/485
	LAN	2 x RJ-45
	Audio/ Video	3.5mm phone jack connector x 2 (Line-out, Mic-in)/ DP x 2
	Control Keys	Rear bottom: Power on /off
Power	Power input	DC-in x 1, 7~32V
	Power adapter	External, 60 watts, universal 100 ~240V AC in, 12V DC out, 6.66A
Environmental	Temperature	Operating Temperature: 12V DC Input 0~50 °C (air flow cooling) Storage Temperature: -20~60°C
	Humidity	Operating & Storage: 10 ~ 90%, non-condensing
	Water/Dust resistance	IP66 at front
Mechanical Characteristics	Housing	Front bezel is Aluminum, others are SECC with black coating
	Dimensions (Net: mm)	398 (H) x 330 (V) x 86 (T)
	Weights (Net: kg)	6 kg
	Mounting	Chassis, VESA (75x75)
Certification	CE/ FCC/ VCCI Class B	

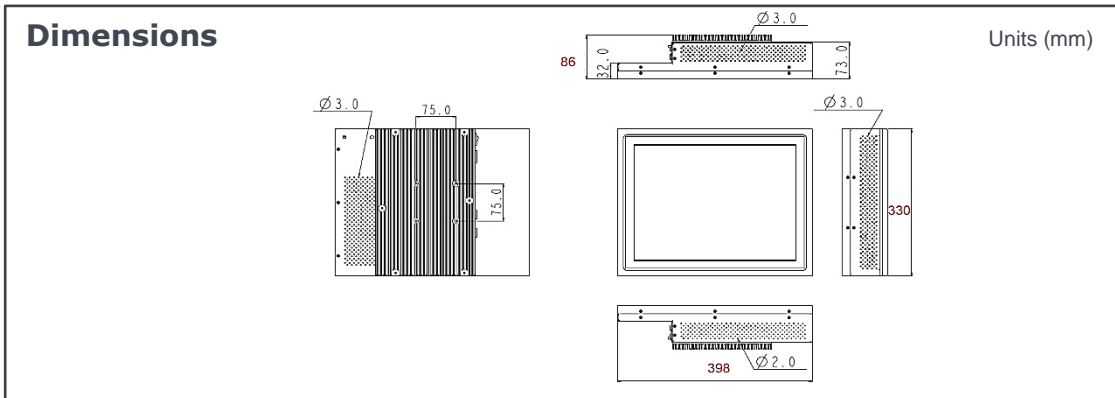

Major Options

Add On Parts	<ol style="list-style-type: none"> 1. Wireless or Wireless + BT kit , 2. mSATA module, 3. Stainless front bezel, 4. Silver front bezel, 5. TPM 2.0, 6. 2.5" SSD, 7. 300 nits LCD Panel
Add On Cable	1.DC input power plug (black, 1.22m length)
Customized	<ol style="list-style-type: none"> 1. Open frame housing, 2. Sunlight readable optical bonding, 3. LCD auto dimming, 4. LCD super dimming (Low brightness), 5. Storage door Solution

Order Information

Item	Touch	Description
WLP-7D20-15 (CKPT)	Chassis P-cap.touch	15" Core i5-5200U/ 4G RAM/ 500G HDD

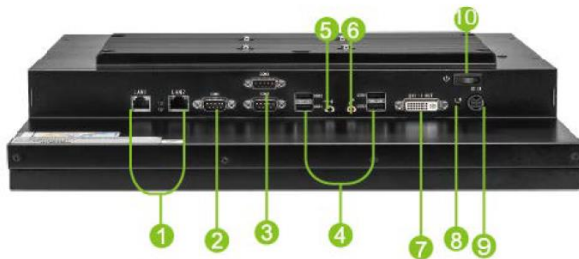

- ① LAN x 2
- ② RS232/422/485
- ③ RS232 x 2
- ④ USB x 4
- ⑤ Line out
- ⑥ Microphone-in
- ⑦ DVI-I
- ⑧ Reset
- ⑨ DC-in
- ⑩ Power on/off



Stainless front bezel (Option)