



Features

- Intel® Broadwell Core i7/i5 CPU
- 19" 1000nits Sunlight Readable LCD
- Wide Temp. -20~60°C Operation
- Full Flat Resistive Touch with Front IP66
- Front Panel Mount Housing
- Optional Mini-PCle WLAN with External Antenna
- Optional 2nd HDD

Specification

Product		WLP-7D20-19H BKFT
Main System	CPU	Intel® 5th generation Core i7/i5/i3 processor
	Graphic	Intel® integrated HD Graphics by CPU
	Memory	Two 1600 MHz DDR3L SODIMM socket support dual Channel, non-ECC, up to 16GB
	OS Support	Win 7, Win 7pro, Win 8, Win 8 industrial, Win10
Display	Size	19"4:3
	Resolution (pixel)	1280 x 1024 (SXGA)
	Number of Colors	16.7M colors
	View Angle (H/V)	170(H) / 160(V)
	Brightness(cd/m ² , nit)	1000 nits
	Contrast Ratio	1000:1 (Typ)
Touch Panel	Type	Full flat resistive touch panel
	Light Transmission	80 ± 5%
	Hardness	4H
	Lifetime	35M times
Storage & Expansion	Storage	128GB 2.5" SATA SSD 3MG2-P x 1
	Expansion	Mini PCIe x 2
I/O Ports	USB	USB 3.0 x 2, USB2.0 x 2
	COM	2 X RS-232, 1 X RS-232/422/485
	LAN	2 x RJ-45
	Audio/ Video	3.5mm phone jack connector x 2 (Line-out, Mic-in)/ DP x 2
	Control Keys	Rear bottom: Power on /off
Power	Power input	DC-in x 1 , 7 ~ 32V
	Power adapter	External, 80 watts, universal 100 ~240V AC in, 12V DC out, 6.66A
Environmental	Temperature	Operating Temperature: 12V DC Input -20~60°C (IEC 60068-2-56 air flow cooling) Storage Temperature: -20~60°C
	Humidity	Operating & Storage: 10 ~ 90%, non-condensing
	Water/Dust resistance	IP66 at front
Mechanical Characteristics	Housing	Front bezel is Aluminum, others are SECC with black coating
	Dimensions (Net: mm)	495.5 (H) x 384.7 (V) x 91.5 (T)
	Weights (Net: kg)	9.2 kg
	Mounting	Panel mount, VESA (75x75)
Certification	CE/ FCC/ VCCI Class B	

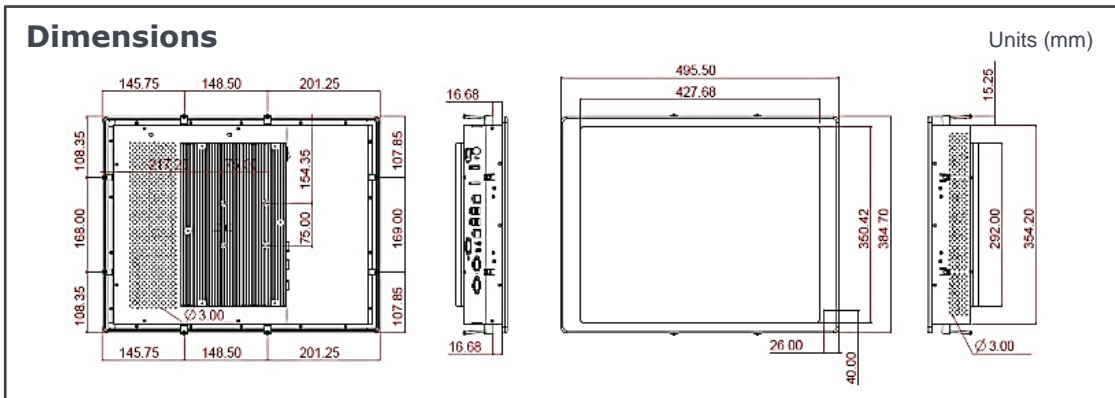

Major Options	
Add On Parts	<ol style="list-style-type: none"> 1. Wireless or Wireless + BT kit , 2. Change to P-cap touch, 3. Stainless front bezel, 4. Silver front bezel, 5.. 2.5" SSD, 6. mSATA module, 7. TPM
Add On Cable	1.DC input power plug (black, 1.22m length)
Customized	<ol style="list-style-type: none"> 1.Open frame housing, 2.Sunlight readable optical bonding, 3.LCD auto dimming, 4.LCD super dimming (Low brightness), 5.Storage door solution, 6. Chassis type housing

Order Information

Item	Touch	Description
WLP-7D20-19H (BKFT)	Full flat Resis. touch	19" Core i5 5200U/ Wide temp. 4G RAM/ 128G SSD

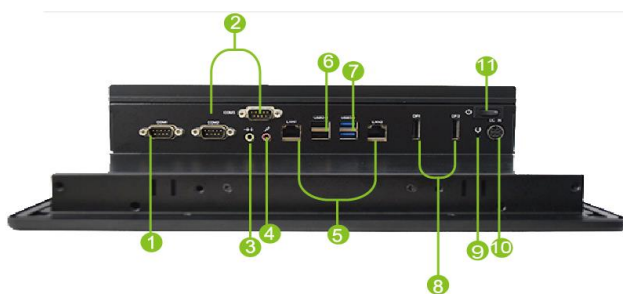

- ① RS232/422/485
- ② RS232 x 2
- ③ Line out
- ④ Microphone-in
- ⑤ LAN x 2
- ⑥ USB 2.0 x 2
- ⑦ USB 3.0 x 2
- ⑧ DP x 2
- ⑨ Reset
- ⑩ DC-in
- ⑪ Power on/off



High Brightness