



Features

- 15" Intel® Atom E3845 Fanless Stainless Panel PC
- IP66/IP69K Full Sealed with Anti-Corrosion Enclosure
- Optional IP67 M12 Stainless Connectors
- Optional Cable Gland for External I.O.
- 100% Waterproof Guarantee
- Wide Temp. -20~50°C Operation Capability
- Screen Touch Lock Function
- CE, FCC, VCCI Class B Certified

Specification

Product		WTP-8B66-15W
Main System	CPU	Intel® Atom E3845 processor
	Graphic	Intel® Graphics HD
	Memory	Two DDR3 SODIMM socket support up to 8GB DDR3L-1333
	OS Support	Win 7, Win 7 Pro, Win8.1, Win 10
Display	Size	15" 4:3
	Resolution (pixel)	1024 x 768 (XGA)
	Number of Colors	16.7M colors
	View Angle (H/V)	160(H) / 160(V)
	Brightness(cd/m ² , nit)	400 nits
	Contrast Ratio	600 : 1 (Typ)
Touch Panel	Type	Full flat resistive touch panel
	Light Transmission	80 ± 5%
	Hardness	4H
	Lifetime	490,000 hours
Storage & Expansion	Storage	WT 128GB 2.5" SATA SSD 3MG2-P x 1
	Expansion	Mini PCIe x 2 (half/full size)
I/O Ports	USB	1 x M12 8pin for USB 1/2, 1 x M12 8pin for USB 3/4
	COM	1 x M12 8pin for COM 1/RS-232/422/485 , 1 x M12 8pin for COM 2/RS-232
	LAN	1 x M12 8pin
	DC in	1 x M12 5pin DC power connector
	Control Keys	Rear bottom: Power on /off
Power	Power input	DC 7V~32V
	Power adapter	AC90~264V/ 47 ~ 63 Hz / DC output 12V, IP67, 60W
	Power consumption	36.1W
Environmental	Temperature	Operating Temperature -20~50°C (12V DC) Storage Temperature -20~60°C
	Humidity	Operating & Storage: 10 ~ 90%, non-condensing
	Water/Dust resistance	IP66 / NEMA4X / IP69K whole set
Mechanical Characteristics	Housing	Stainless steel (SUS304), chassis type
	Dimensions (Net: mm)	395 x 309.5 x 58
	Weights (Net: kg))	7.6 kg
	Mounting	VESA 100/100, Side mount (M6*2)
Certification	CE/ FCC/ VCCI Class B, Canada ICES-003	

WTP-8B66-15W

Stainless Steel Panel PC

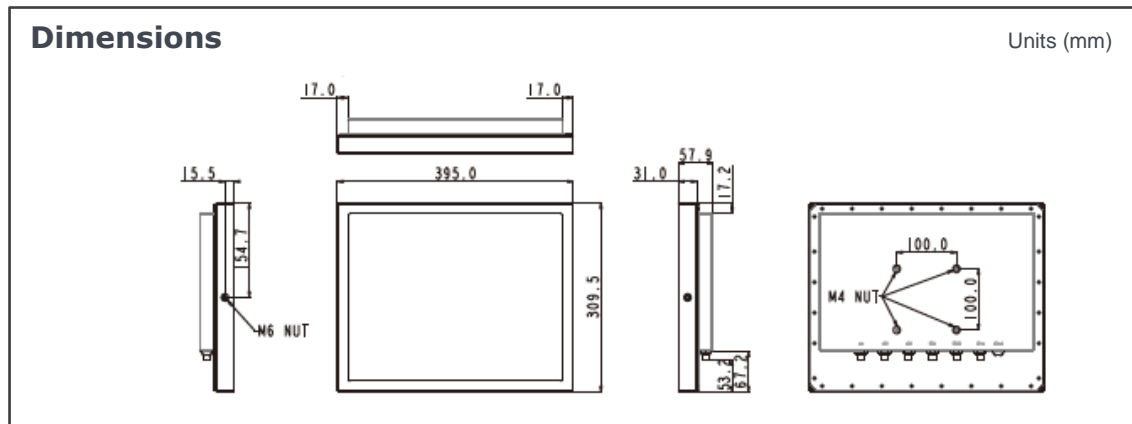

Major Options	
Add On Parts	1. Wireless LAN or Wireless and BT kit (Easy Clean and Robust Antenna or 2 ant), 2. SSD, 3. Stainless M12 connector, 4. Cable Gland for External I.O.
Add On Cable	1. COM cable (2 meters) x 1, 2. USB cable (2 meters) x 1, 3. LAN cable (2 meters) x 1
Optional kits	1. Wall mount / Table mount bracket
Customized	1. Sunlight readable optical bonding, 2. 1000 nit high brightness LCD, 3. LCD Auto dimming, 4. LCD Super dimming (Low brightness), 5. 5W/2W Speaker, 6. Second HD, 7. Intel Core i7-6500U, 8. COM + power 5V or 12V, 9. Barcode reader, 10. TPM, 11. External LAN x 2, 12. Waterproof USB 3.0, 13. IP67, 14. SUS316 Enclosure

Order Information

Item	Cooling	Description
WTP-8B66-15W	Fanless	15" E3845 / DDR3L 2GB RAM/ WT 128G SSD/ full flat R-touch

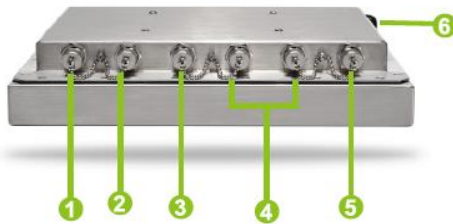

- 1 Giga LAN
- 2 USB 1/2
- 3 USB 3/4
- 4 COM x 2
- 5 DC-in
- 6 Power on/off

