



Features

- 21.5" Intel® Apollo Lake J3455 Fanless Stainless Panel PC
- IP66/IP69K Full Sealed with Anti-Corrosion Enclosure
- Special Inspection of 100% Waterproof Guarantee
- Optional IP67 M12 Stainless Connectors
- Optional Cable Gland for External I.O.
- Optional Waterproof USB 3.0
- Car Ignition Control & PoE for Customization
- CE, FCC, VCCI Class B Certified

Specification

Product		WTP-8D66-22
Main System	CPU	Intel® Apollo Lake Celeron Processor J3455 10W / SoC
	Graphic	Intel® Graphics HD 500
	Memory	Single channel support 1867MHz DDR3L SODIMM socket, up to 8GB
	OS Support	Win 10 (Option)
Display	Size	21.5" 16:9
	Resolution (pixel)	1920 x 1080 (FHD)
	Number of Colors	16.7M colors
	View Angle (H/V)	170(H) / 160 (V)
	Brightness (nit)	250
	Contrast Ratio	1000:1 (Typ)
Touch Panel	Type	Full flat resistive touch panel
	Light Transmission	80 ± 5%
	Hardness	≥3H
	Lifetime	35M hours
Storage & Expansion	Storage	2.5" SATA HDD drive bay x 1, M.2 SATA III SSD 2280 slot x 1
	Expansion	M.2(E key 2230) x 1, Mini-PCIe 52 pin x 1
I/O Ports	USB	1 x M12 8pin for USB 1/2, 1 x M12 8pin for USB 3/4
	COM	1 x M12 8pin /RS-232/422/485 , 1 x M12 8pin /RS-232
	LAN	1 x M12 8pin for LAN
	DC in	1 x M12 5pin DC power connector
	Control Keys	Rear bottom: Power on /off
Power	Power input	DC 9V~32V
	Power adapter	AC 90~264V / 47 ~ 63 Hz / DC output 12V, 60W (IP68 PSU w/ PSE)
	Power consumption	40.6 W
Environmental	Temperature	Operating Temperature 0~45°C (12V DC) Storage Temperature -20~60°C
	Humidity	Operating & Storage: 10 ~ 90%, non-condensing
	Water/Dust resistance	IP66 / NEMA4X / IP69K whole set / IK05
Mechanical Characteristics	Housing	Stainless steel (SUS304), chassis type
	Dimensions (Net: mm)	557 x 348.5 x 58.5
	Weights (Net: kg)	12kg
	Mounting	VESA 100*100, Side mount (M6 x 2)
Certification	CE/ FCC/ VCCI Class B, Canada ICES-003	

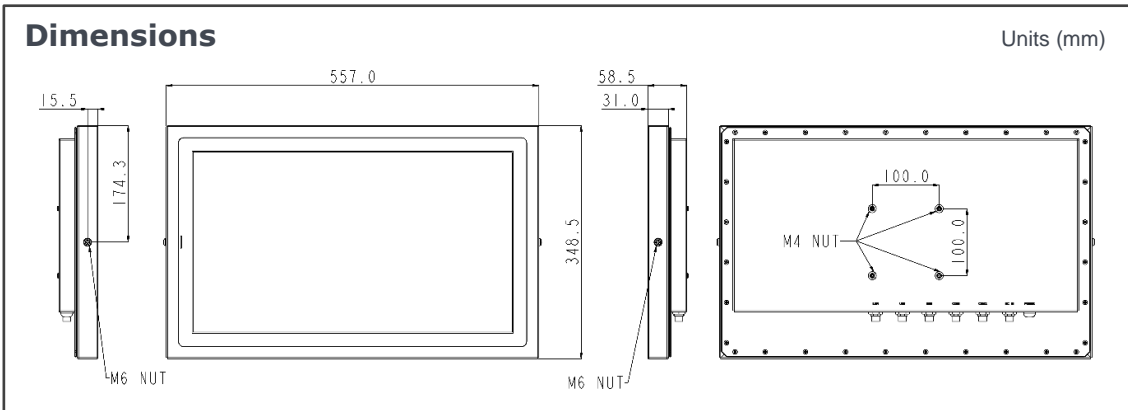

Major Options	
Add On Parts	<ul style="list-style-type: none"> ① Wireless LAN or Wireless and BT kit (Easy Clean and Robust Antenna) ② M.2 SSD, ③ External LAN x 2, ④ Waterproof USB 3.0, ⑤ Stainless M12 connector ⑥ TPM2.0, ⑦ IP67, ⑧ Full Flat PCT Touch Screen IP69K ⑨ SUS316 Enclosure ⑩ 2.5" SSD, ⑪ Cable Gland for External I.O.
Add On Cable	<ul style="list-style-type: none"> ① Waterproof USB cable, cable length is 2 meters ② Waterproof LAN cable, cable length is 2 meters ③ Waterproof COM cable, cable length is 2 meters ④ DC input cable ⑤ Maximum length is 5.2 meters by 2x2m DC cables
Optional Kits	<ul style="list-style-type: none"> ① Wall mount / Table mount bracket
Customized	<ul style="list-style-type: none"> ① Sunlight readable optical bonding (Impact Protection Level : IK08) ② 1000 nit high brightness LCD ③ LCD Auto dimming ④ 5W/2W Speaker ⑤ PoE ⑥ Second HD for RAID 0,1 ⑦ COM + power 5V or 12V ⑧ Barcode reader ⑨ Car ignition power control

Order Information

Item	Cooling	Description
WTP-8D66-22-Resis	Fanless	22"J3455 / DDR3L 4G RAM / 500G HDD / Resistive touch
WTP-8D66-22-PCT	Fanless	22"J3455 / DDR3L 4G RAM / 500G HDD / P-cap touch



- ① Giga LAN
- ② USB 1/2
- ③ USB 3/4
- ④ COM x 2
- ⑤ DC-in
- ⑥ Power on/off

