



Features

- 15" Intel® Broadwell Fanless Stainless Panel PC
- IP66 Full Sealed with Anti-Corrosion Enclosure
- Support Intel® vPro Technology by CPU
- IP67 M12 Stainless Connectors
- Wide Temp. -20~55°C Operation Capability
- Special Inspection of 100% Waterproof Guarantee
- CE, FCC, VCCI Class B Certified

Specification

Product		WTP-9C66-15	WTP-9C66-15W
Main System	CPU	Intel® Broadwell core i7/ i5 processor	
	Graphic	Intel® Graphics HD	
	Memory	Two 1600 MHz DDR3L SODIMM socket support dual Channel, non-ECC, up to 16GB	
Display	Size	15" 4:3	
	Resolution (pixel)	1024 x 768 (XGA)	
	Number of Colors	16.7M colors (RGB 6-bit + Hi FRC)	
	View Angle (H/V)	160(H) / 160(V)	
	Brightness(cd/m ² , nit)	450 nits	
	Contrast Ratio	600 : 1 (Typ)	
Touch Panel	Type	Full flat resistive touch	
	Light Transmission	80 ± 5%	
	Lifetime	350,000 times	
Storage & Expansion	Storage	2.5" SATA HDD 500G	2.5" SATA SSD 128GB
	Expansion	Mini PCIe x 2	
I/O Ports	USB	2 x M12 8pin	
	COM	1 X M12 8pin/ RS-232 1 X M12 8pin/ RS-232/422/485	
	LAN	1 x M12 8pin	
	DC in	1 x M12 5pin DC power connector	
	Control Keys	Rear bottom: Power on /off	
Power	Power input	DC 7V~32V	
	Power adapter	AC90~264V/ 47 ~ 63 Hz / DC output 12V	
	Power consumption	39.3W	
Environmental	Temperature	Operating Temp. 0~40°C/ 0~50°C(change HDD to SSD) Storage Temp. -20~60°C	Operating Temp. -20°C~55°C Storage Temp. -20°C~60°C
	Humidity	Operating & Storage: 10 ~ 90%, non-condensing	
	Water/Dust resistance	IP66 whole set	
Mechanical Characteristics	Housing	Stainless steel (SUS304)	
	Dimensions (Net: mm)	395 x 309.5 x 58	
	Weights (Net: kg))	8.4kg	
	Mounting	VESA 100*100	
Certification	CE/ FCC/ VCCI Class B		

WTP-9C66-15(W)

Stainless Steel Panel PC

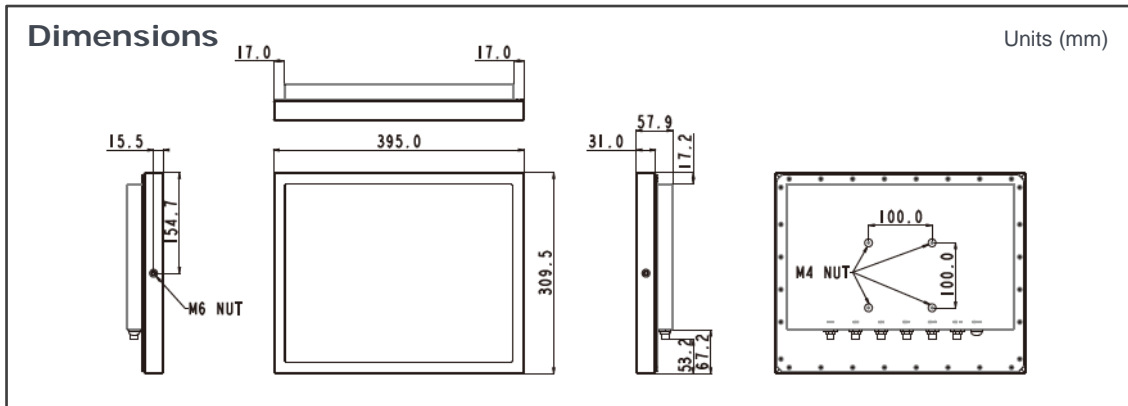

Major Options	
Add On Parts	1.Wireless or Wireless and BT kit (2 ant), 2.SSD, 3. Robust Antenna, 4.USB 3.0
Power Cable	1.Waterproof COM cable x 1, 2.Waterproof USB cable x 1, 3. Waterproof LAN cable x1 4. External LAN x 2
Optional kits	1.Wall mount/ Table mount bracket
Customized	1.sunlight readable optical bonding, 2.full flat PCT touch screen IP69K, 3.1000 nit high brightness LCD , 4.LCD Auto dimming, 5.LCD Super dimming (Low brightness) , 6.Speaker, 7.IP67, 8.Second HD, 9.Intel Core i7-6500U ,10.2 External LAN, 11.COM+power 5V or 12V, 12.SUS316 enclosure, 13.Barcode reader, 14.TPM

Order Information

Item	Cooling	Description
WTP-9C66-15 (i5)	Fanless	15" Core i5-5200U / DDR4 4G RAM/ 500G HDD/ full flat R-touch
WTP-9C66-15W (i5)	Fanless	15" Core i5-5200U / DDR4 4G RAM/ 500G HDD/ full flat R-touch



- 1 Giga LAN
- 2 USB 1/2
- 3 USB 3/4
- 4 COM x 2
- 5 DC-in
- 6 Power on/off

