



Features

- 15" Intel® 6th/7th Generation Fanless Stainless Panel PC
- IP66/69K Full Sealed with Anti-Corrosion Enclosure
- Support Intel® vPro technology by CPU
- IP67 M12 Stainless/Metal Connectors
- Optional Cable Gland for External I.O.
- 100% Waterproof Guarantee
- CE, FCC, VCCI Class B Certified
- Screen Touch Lock Function

Specification

| Product | | WTP-9E66-15 | |
|----------------------------|----------------------------------------|--------------------------------------------------------------------------------------------------|----------------------------|
| Main System | CPU | Intel® 6 th /7 th generation core i7/i5 processor | |
| | Graphic | Intel® Graphics HD | |
| | Memory | Two DDR4 SODIMM socket support dual Channel, up to 32GB | |
| | OS Support | Optional Windows 7 embedded, Windows 7 pro, Windows 8 embedded, Windows 8 industrial, Windows 10 | |
| Display | Size | 15" 4:3 | |
| | Resolution (pixel) | 1024 x 768 (XGA) | |
| | Number of Colors | 16.7M colors (RGB 6-bit + Hi FRC) | |
| | View Angle (H/V) | 160(H) / 160(V) | |
| | Brightness (nit) | 350 nits | |
| | Contrast Ratio | 800 : 1 (Typ) | |
| Touch Panel | Type | Full flat resistive touch panel | Projected Capacitive Touch |
| | Light Transmission | 80 ± 5% | 90±3% |
| | Hardness / Lifetime | 4H / 35M times | 7H / 100M times |
| Storage & Expansion | Storage | 2.5" SATA HDD or SSD | |
| | Expansion | Mini PCIe x 1 M.2 Type E x 1 | |
| I/O Ports | USB | 1 x M12 8pin for USB 1/2, 1 x M12 8pin for USB 3/4 | |
| | COM | 1 X M12 8pin for COM 1/RS-232, 1 X M12 8pin for COM 2/RS-232/422/485 | |
| | LAN | 1 x M12 8pin for LAN x 1 (i219LM for Vpro) | |
| | DC in | 1 x M12 5pin DC power connector, DC 9~32V | |
| | Control Keys | Rear bottom: Power on /off | |
| Power | Power adapter | AC 100 ~ 277V / 47 ~ 63 Hz / DC output 24V, 5A, 120W, IP68 | |
| | Power consumption | 53.8W | |
| Environmental | Temperature | Operating Temperature 0~40°C/ 0~50°C(change to SSD) Storage Temperature -20~60°C | |
| | Humidity | Operating & Storage: 10 ~ 90%, non-condensing | |
| | Water/Dust resistance | IP66 / NEMA4X / IP69K whole set | |
| Mechanical Characteristics | Housing | Stainless steel (SUS304), chassis type | |
| | Dimensions (Net: mm) | 395 x 309.5 x 58 | |
| | Weights (Net: kg)) | 8.4kg | |
| | Mounting | VESA 100*100, side mount (M6*2) | |
| Certification | CE/ FCC/ VCCI Class B, Canada ICES-003 | | |

WTP-9E66-15

Stainless Steel Panel PC

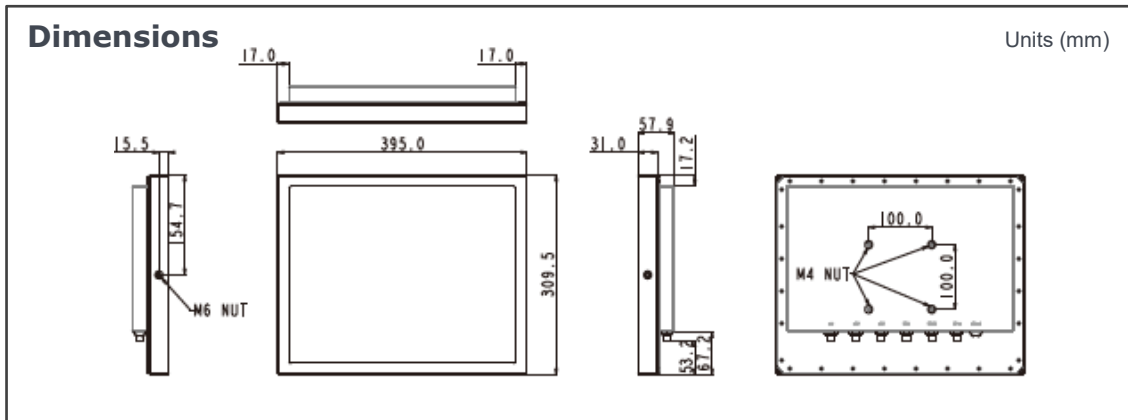

| Major Options | |
|---------------|---------------------------------------------------------------------------------------------------------------------------------------------------------------------------------------------------------------------------------------------------------------------------------|
| Add On Parts | 1. Wireless LAN or Wireless and BT kit (Easy Clean and Robust Antenna or 2 ant), 2. SSD, 3 External LAN x 2, 4. Waterproof USB 3.0, 5. Stainless M12 connector, 6. TPM2.0, 7. IP67, 8. Full Flat PCT Touch Screen IP69K, 9. SUS316 Enclosure, 10. Cable Gland for External I.O. |
| Power Cable | 1. Waterproof M12 to 1 x COM cable, 2. Waterproof M12 to 1 x USB cable, 3. Waterproof M12 to 1 x LAN cable, 4. Maximum length is 5.2 meters by 2x2m DC cables |
| Optional kits | 1. Wall mount/ Table mount bracket |
| Customized | 1. Sunlight readable optical bonding, 2. 1000 nit high brightness LCD, 3. LCD Auto dimming, 4. LCD Super dimming (Low brightness), 5. 5W/2WSpeaker, 6. Second HD, 7. COM + power 5V or 12V, 8. Barcode reader |

Order Information

| Item | Cooling | Description |
|------------------|---------|--------------------------------------------------------------|
| WTP-9E66-15 (i5) | Fanless | 15" Core i5-7200U / DDR4 4G RAM/ 128G SSD/ full flat R-touch |

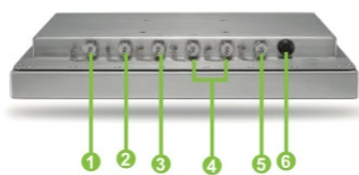

- ① Giga LAN
- ② USB 1/2
- ③ USB 3/4
- ④ COM x 2
- ⑤ DC-in
- ⑥ Power on/off

